



DESIGN NOTES

Microprocessor Core Supply Voltage Set by I²C™ Bus Without VID Lines – Design Note 279

Mark Gurries

Introduction

Many modern CPUs run at two different clock speeds, where each speed requires a different core operating voltage to assure optimum performance. These voltages are documented in the manufacturer's VID (voltage identification) section of the CPU specification. Some new DC/DC converters (the LTC®1909, for example) have built-in VID control that supports dual programmable output voltages, but many existing converters do not. The LTC1699 is a precision 2-state resistive divider that uses a simple SMBus interface to allow VID control on non-VID-enabled DC/DC converters. No dedicated VID lines are required.

How it Works

DC/DC converters maintain consistent output voltage by comparing the output voltage, through an accurate voltage divider, against an internal reference and adjusting the output to compensate for differences. The LTC1699 is a 2-state resistive divider that replaces the fixed voltage divider in the feedback circuit, thus allowing the circuit to support two different voltage outputs. It is specifically designed to work with DC/DC PWM converters that use an internal 0.8V reference, such as the LTC1702A, LTC1628, LTC1735 and the LTC1778.

The LTC1699, on command, can choose between two programmable, precision output voltages. The two voltages are programmed via 5-bit VID words sent over the commonly used SMBus (System Management Bus) serial interface, precluding the need for dedicated VID control lines. The host system then has two methods to switch between the two voltages: digitally through the SMBus interface or via a logic signal at the select (SEL) pin. When CPU voltage is in regulation, the LTC1699 provides a power good signal that can be used to inform the CPU and satellite systems that power is up to specification. An enhanced version of the IC, the LTC1699EGN, expands the power sequencing control and status lines to coordinate multiple DC/DC converters that manage other CPU system voltages, such as those for the I/O and clock supplies (see Figure 2).

Since accurate CPU voltages are critical for reliable CPU operation, the voltage dividers in the LTC1699 are accurate to within $\pm 0.35\%$. There are three versions of the LTC1699 to support different Intel CPUs and the unique voltage tables based on their 5-bit VID codes. The LTC1699-80 covers the Intel mobile specification while the desktop standards are covered by the LTC1699-81 for the VRM8.4 specification, and the LTC1699-82 for VRM9.0 specification (see Table 1).

LT, LTC and LT are registered trademarks of Linear Technology Corporation. I²C is a trademark of Philips Electronics N.V.

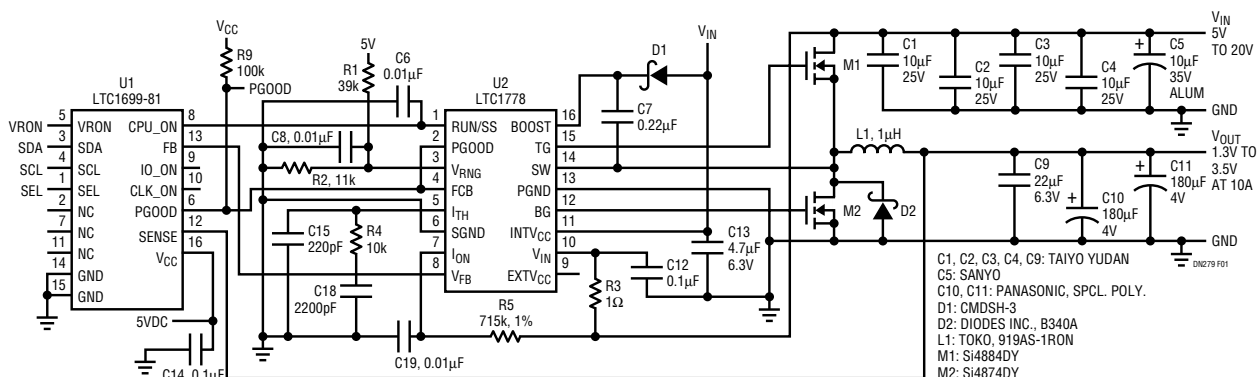

Figure 1. SMBus Controlled High Efficiency DC/DC Converter

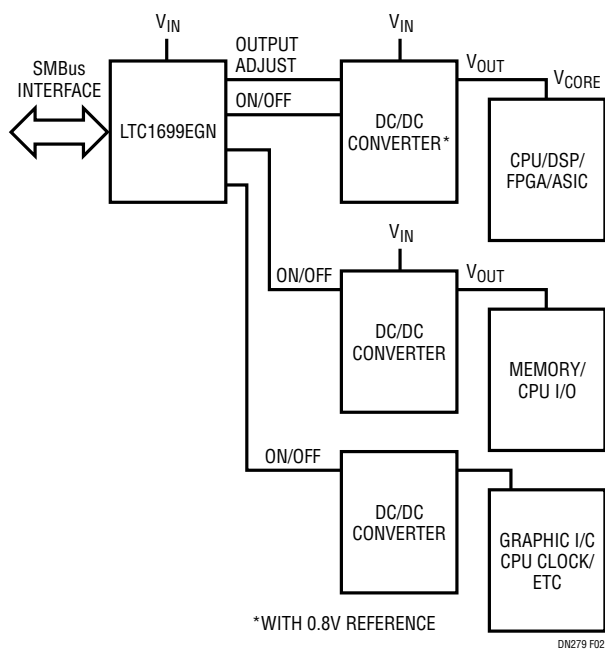

Figure 2. SMBus Power Sequencing and Multiple DC/DC Converter Control with the 16-Pin SSOP Package of the LTC1699EGN

Table 1. Selection of V_{OUT} Ranges and VRMs with the Combination of the LTC1699 and an Appropriate DC/DC Converter

PART NUMBER	V_{OUT} RANGE	VRM COMPATIBILITY
LTC1699-80	0.9V to 2.0V	Mobile CPU
LTC1699-81	1.3V to 3.5V	VRM8.4
LTC1699-82	1.075V to 1.85V	VRM9.0

Why Use an SMBus?

An SMBus is easy to implement and is growing as a system control standard. The SMBus was developed as a low power 2-wire serial interface to standardize the control and monitoring of the system support functions other than the CPU, originally defined for portable computers with intelligent rechargeable batteries. Most portable computers today use the SMBus for more than just battery control. It has evolved as the standard method of power flow control, system temperature monitoring and cooling

control. It is now supported by popular operating systems and is integral to current PC design standards. Controlling the CPU voltage via SMBus is the next logical step, eliminating the need for proprietary control interfaces.

The SMBus does have some limitations. The SMBus version 1.0 standard has no error checking protocol, a potentially significant problem for modern CPUs that do not fare well when provided the wrong voltage. Although the newer SMBus v1.1 standard includes an optional error checking protocol, it is not widely used. Because most systems that traditionally use SMBus are error tolerant, upgrading current designs to the SMBus v1.1 protocol means a significant increase in communications software and hardware complexity. To address these issues and still take advantage of SMBus benefits, Linear Technology has developed several special protocol procedures and recommendations that provide ways to eliminate errors without use of v1.1 error checking.

The first is to allow the host to write and read the preprogrammed voltage values as often as needed to verify the value. The second is that a programmed value is not activated until the host sends two SMBus "ON" or "OFF" commands, one after the other. If any bit is out of place in the "ON" or "OFF" values, the preceding voltage programming command is rejected.

The LTC1699 also features two special lockout functions. The first is to ignore "ON" commands until the voltage registers are set up. In addition, when two valid "ON" command sequences are received, the VID registers are locked out to prevent changes while the power supplies are operating. Finally, the LTC1699 implements the new SMBus v1.1 logic levels for improved signaling integrity. Together these techniques offer robust and safe control of the CPU voltage using the popular SMBus.

Desktop/Portable VID DC/DC Converter

Figure 1 shows a typical implementation of a core voltage regulator using the LTC1778 controller and the LTC1699. The equivalent circuit is available as a monolithic IC in the LTC1909.

Data Sheet Download

<http://www.linear.com/go/dnLTC1699>

For literature on our SMBus VID Voltage Programmers, call **1-800-4-LINEAR**. For applications help, call (408) 432-1900, Ext. 2593